



Cowellmedi Co., Ltd.
The pioneers in Dental Implant & E.rhBMP-2



COWELL® InnoGenic™

Wifi-Mesh

Wifi-shaped Titanium reinforced PTFE Membrane

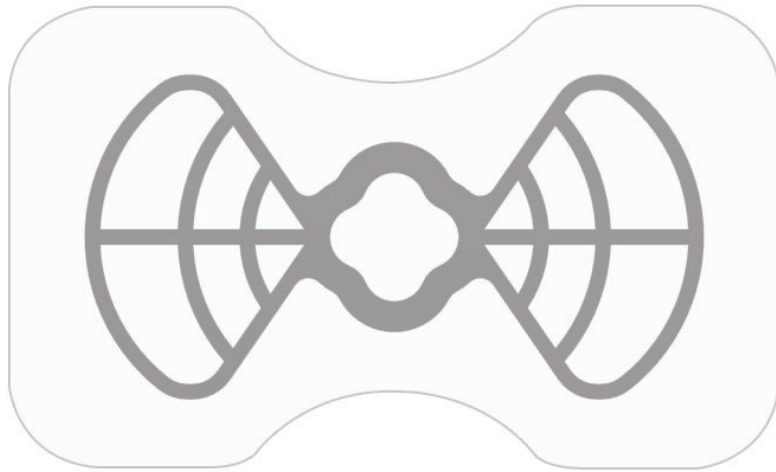

Looking for results?

ID

Wifi_Mesh



Password

GBR_Master



Connect to Wifi, be a GBR Master

LOGIN

REGISTER



Concept of Barrier Membrane

Which role does barrier membrane play in GBR ?

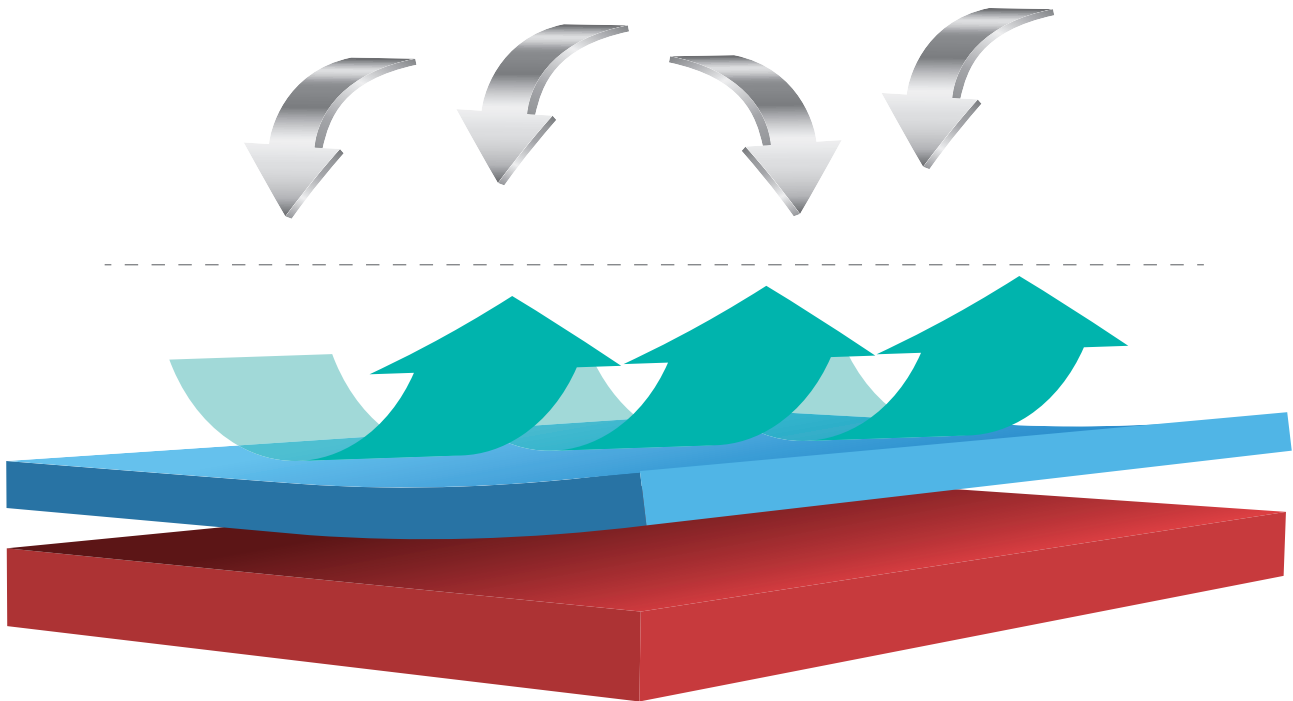

: Physical inhibition of fibrous connective tissue without bone formation capability (gingival epithelia, gingival connective tissue cells), preventing it from penetrating bone defect.

- Fibrous connective tissue is prevented from invading into the bone defect, thereby obtaining sufficient amount of bone formation.
- The penetration of upper gingiva tissue of the bone defect is prevented, so the proliferation of cells derived from the bone tissue in the lower part promotes bone formation.
- Barrier membrane protects the blood clots filling the bone defect and blocks the external force from the upper soft tissue to fix the wound to promote bone regeneration.



Checklist when choosing barrier membrane

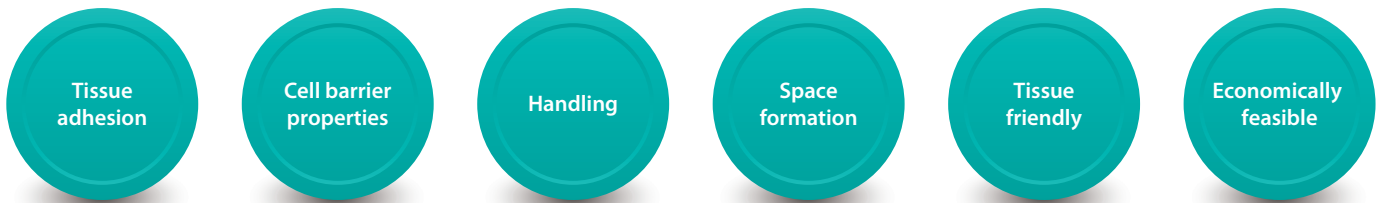

- Tissue adhesion: the membrane should be connected to tissue and not move.
- Cell barrier properties: the membrane allows only osteoblast to proliferate.
- Handling: Easy to handle and cut out.
- Space formation: the membrane must maintain space for bone formation.
- Tissue friendly: No inflammatory response.
- Economically feasible: Price should be affordable to use.

Non-Resorbable VS Resorbable Barrier Membrane in general

	Non-Resorbable	Resorbable
Pros	<ul style="list-style-type: none"> · Highly effective osteoconduction · Excellent capacity of space securement · Clinical predictability · Simple application to vertical augmentation · Possible to set effect continuance time · Stable healing of blood clots 	<ul style="list-style-type: none"> · No 2nd surgery required · Osteoinductive (but very insignificant)
Cons	<ul style="list-style-type: none"> · Hard to observe underlying tissue healing · Hard to remove & 2nd Op. required · Very costly 	<ul style="list-style-type: none"> · Low capacity to secure space · Difficult to precisely remove non completely resorbed membrane caused by exposure · Impossible to observe under-tissue healing · Unpredictable resorption time · Insufficient to use for GBR



Development Background

A barrier membrane that maximizes advantages of non-resorbable & resorbable membrane and minimizes disadvantages !



- 1 For all GBR required cases, in particular, anterior portions requiring a specific shape and a defects with little amount of residual bone.
- 2 Prevention of marginal bone resorption which is the most important in implant treatment by maintaining vertical and horizontal volume of bone regeneration site of alveolar bone ridge.
- 3 Prevention of infection from bacterial adhesion even at early exposure due to non-porous structure.
- 4 Simple removal method and thin thickness make second surgery easy and very convenient for patients and clinicians.
- 5 Almost transparent material provides very much predictable solution and is easy to observe underlying tissue.
- 6 Extremely cost-effective.



Why is it called “Wifi-Mesh”?

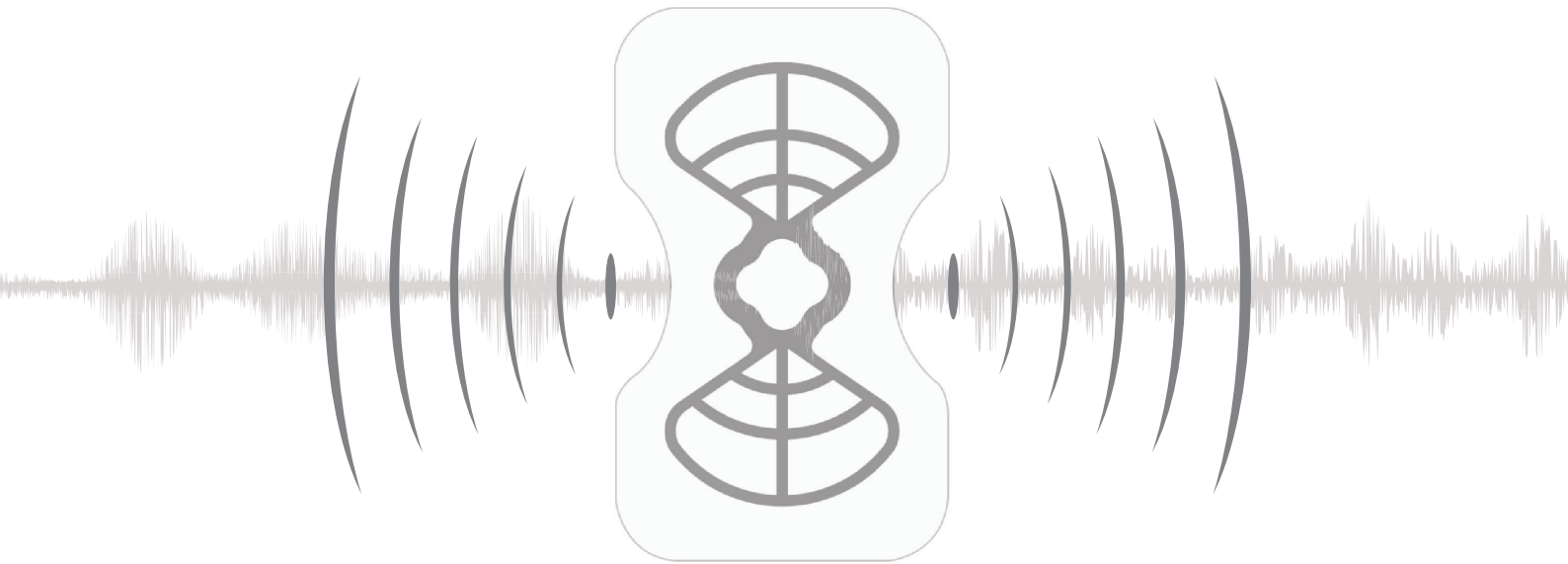

In order to find the most effective shape and favorable materials of the barrier membrane for GBR, many types of materials and their shapes had been tested.



As a result, the Wifi-shaped titanium reinforced PTFE membrane showed the optimal result in inducing osteoconductive bone surface regeneration by communicating with adjacent bone stem cells.



This phenomenon is similar to Wifi with mesh-like communication network that spreads widely into empty space and the shape of the titanium of the product looks like the Wifi symbol. In the light of the phenomenon and appearance, the product was named “**Wifi-Mesh**”.

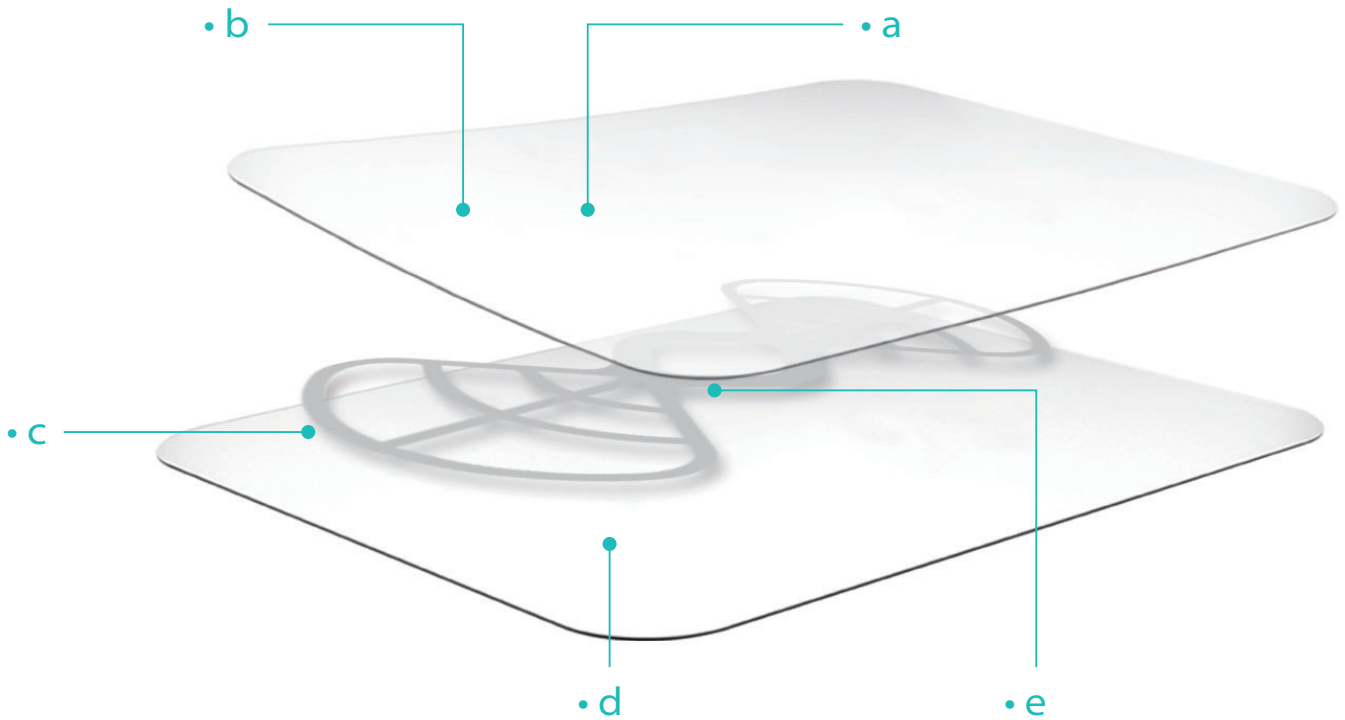

Features



- a. High predictability of results: the transparent PTFE membrane allows the healing process of the underlying tissue to be identified, making it highly predictable and easy to determine removal time.
- b. Prevention of infection: the non-porous and smooth surface prevents bacterial penetration and even it allows users to perform open sheet membrane technique.
- c. Superb shape retentivity: the reinforced titanium frame is easy to bed shaped and maintain superb shape retentivity.
- d. Healing Period Control: the Wifi-Mesh is made of 100% non-resorbable material so that users can control the healing period.
- e. Easy to remove and fix: the hole in the centre allows easy removal and fixation with such bone screws and abutments as BOSS® System.
- f. Various shapes and sizes: available in a variety of shapes and sizes for optimal application (refer to the page 7).

 <p>Quick & simple customization</p>	 <p>Outstanding space maintenance</p>	 <p>The optimal solution for GBR</p>
<p>Anybody can easily cut in the desired shape</p>	<p>Bone graft materials & space are safely protected & secured</p>	<p>Stable healing of blood clots using clinically proven materials</p>



Comparison to different types of Non-resorbable membranes

classification	PTFE-Mesh	Ti-Mesh	Wifi-Mesh
Image			
Cutting Instrument	Dean scissor	SS crown scissor	Dean scissor
Memory	High	Very low	Very low
Space Maintenance	Weak	Strong	Strong
Action on exposure	No need to remove	Immediate removal required	No need to remove
Application of open membrane technique	Possible	Impossible	Possible
Technical experience	Not much required	Highly required	Not much required

Comparison to similar types of Non-resorbable membranes

Classification	Product A	Product B	InnoGenic™ Wifi-Mesh
SEM Photograph			
Ultrastructure	Fiber	Filter	Sheet
Bacterial infection at exposure	Bacterial toxin penetration between filters at 50 μm intervals	Bacterial toxin penetration between filters at 2 μm intervals	No Bacterial toxin penetration thanks to non porous structure
Action on exposure	Instant Removal	Removal on week 3 to 4	Safe for more than 6 weeks
Block function against fiber cell	High	High	Extremely High
Shape-keeping against external force	Large Deformation	Shrinkable Deformation	No Deformation



Specifications



Product Code	Size	Thickness
BTP1424AA	14X24	0.25
BTP1424AB	14X24	0.25
BTP1525BB	15X25	0.25
BTP1725CA	17X25	0.25
BTP2030AB	20X30	0.25
BTP2530AB	25X30	0.25
BTP3040AB	30X40	0.25

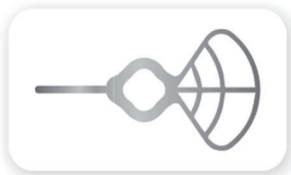

BTP1424AA

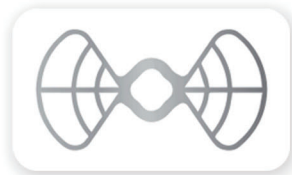

BTP1424AB

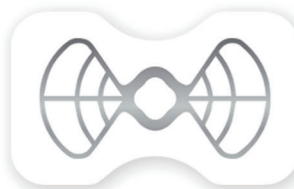

BTP1525BB

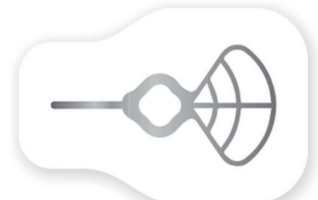

BTP1725CA

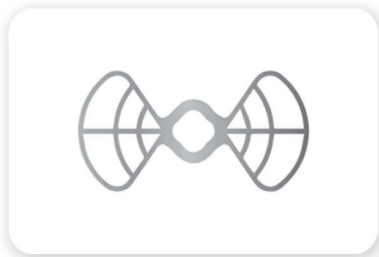

BTP2030AB



BTP2530AB



BTP3040AB



Indications

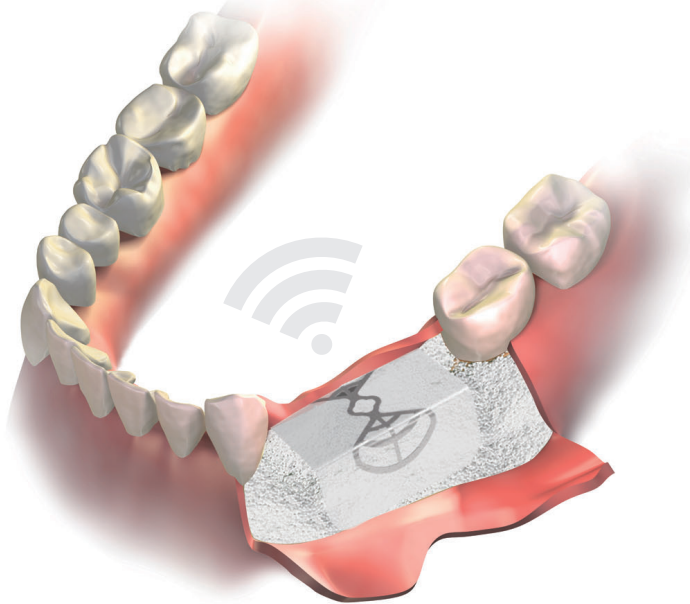

Connect to Wifi,
be a GBR Master !

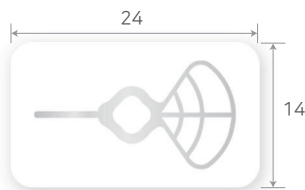

BTP1424AA

Only one wall defect of buccal or lingual bone in very narrow area

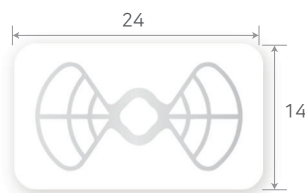

BTP1424AB

Two wall defect of buccal and lingual bone in very narrow area

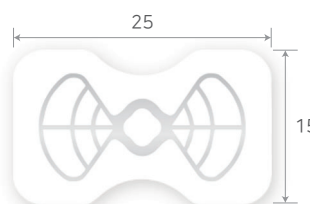



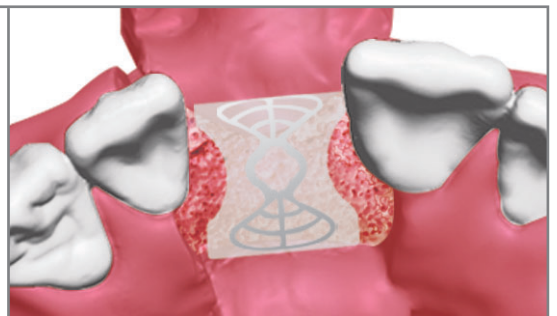

BTP1525BB

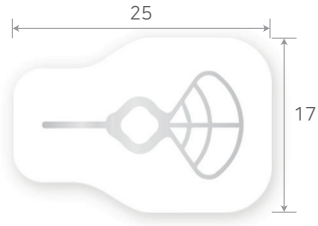

Inter-dental two wall defect of buccal and lingual bone in very narrow area



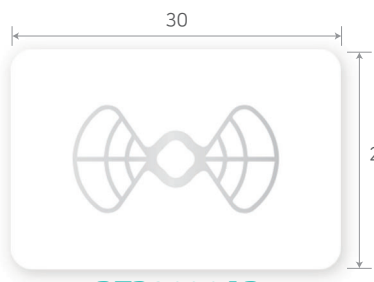



 <p>BTP1725CA</p>	<p>Inter-dental two wall defect of buccal and lingual bone in narrow area</p> 
---	--

 <p>BTP2030AB</p>	<p>Two wall defect of buccal and lingual bone in narrow area</p> 
--	--

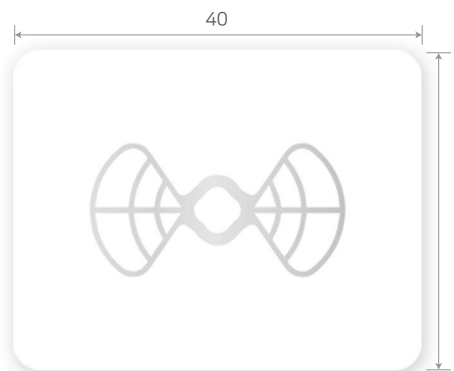
 <p>BTP2530AB</p>	<p>Two wall defect of buccal and lingual bone in large area</p> 
---	--

 <p>BTP3040AB</p>	<p>Two wall defect of buccal and lingual bone in very large area</p> 
---	---



Application using GBR Abutment (BOSS® Type I)



① Pre-OP



② INNO Fixture

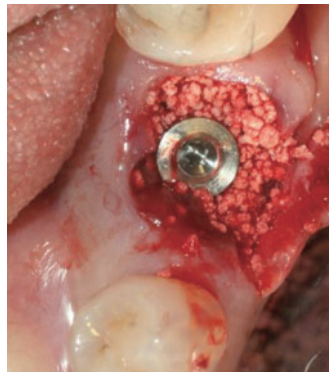

③ BOSS Abutment & bone graft

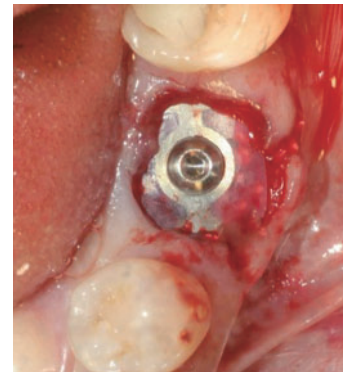

④ BOSS Abutment & Wifi-Mesh



⑤ After 3 weeks



⑥ Removal of Wifi-Mesh

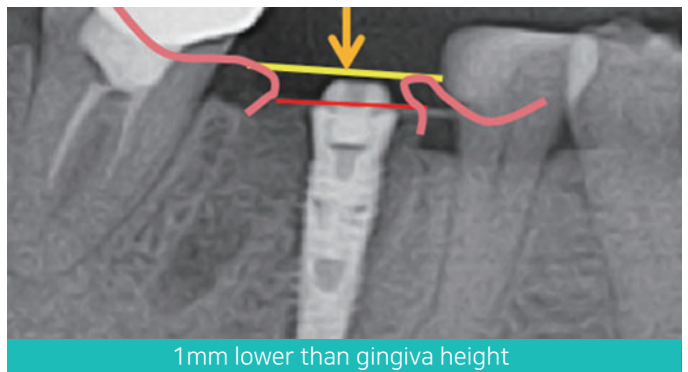

1mm lower than gingiva height

Clinical Consideration when used with GBR Screw & Abutment (BOSS®)

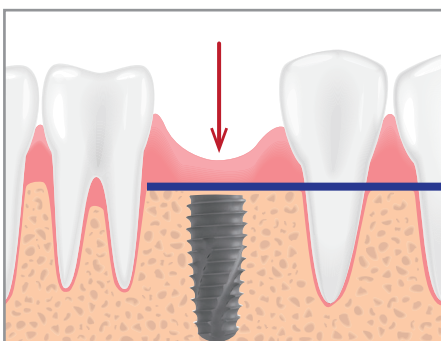

BOSS Abutment Height
1mm lower than gingiva height

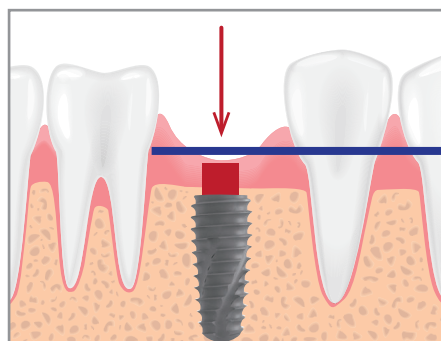

Implant depth
1~2mm deeper than bone Level

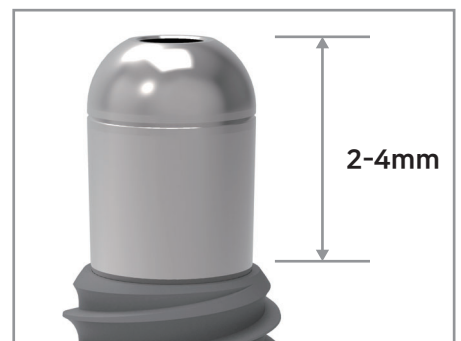

Selection of BOSS Abutment
Depending on the gingival height



Application using GBR Abutment (BOSS® Type II)

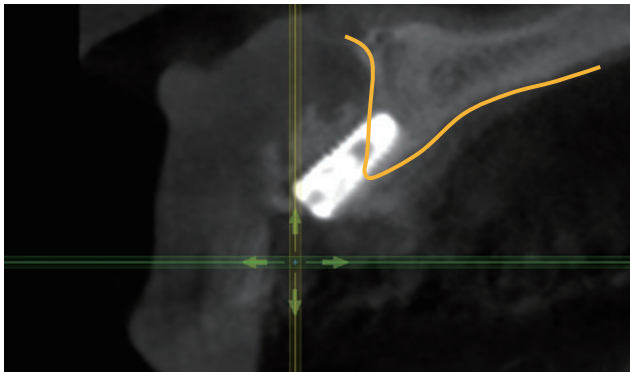

Implant initial fixation impossible due to lack of alveolar bone

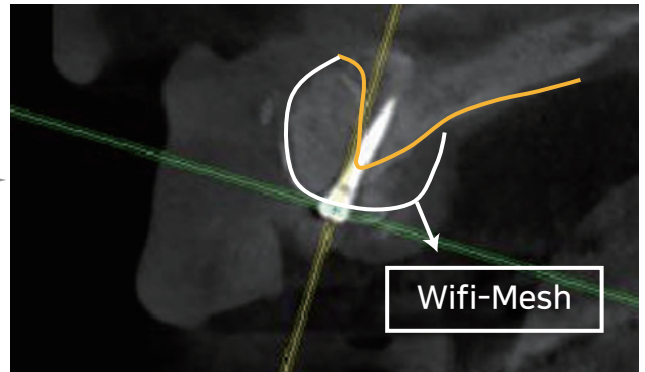

Vertical bone augmentation using the Wifi-Mesh and BOSS Screw

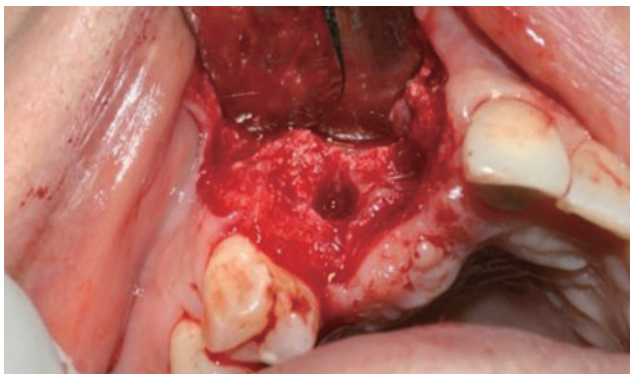

① Implants cannot be placed due to lack of alveolar bone

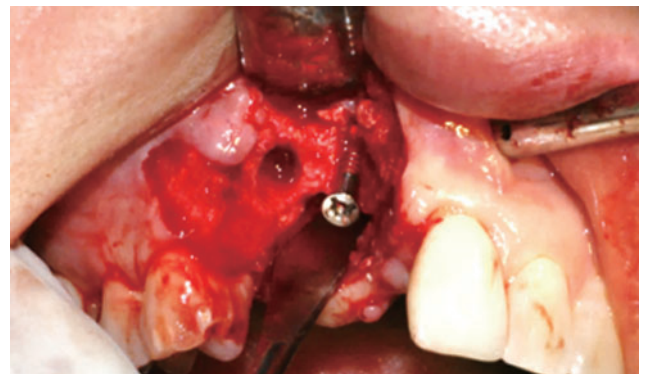

② Fixed to center



③ Bone graft was performed

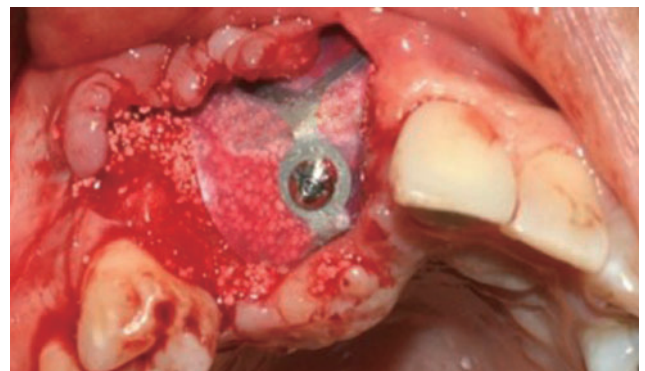

④ Mount the Wifi-Mesh to the Screw using the cover.



Clinical Application

Case I



Pre-op



Implant placement

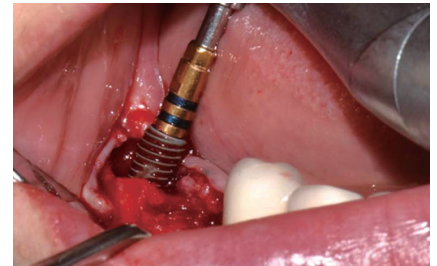

Implant placement

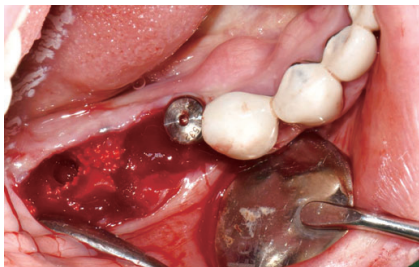

Clinical occlusal view of #45 and #46 showed severe bone defects.



Buccal bone graft technique with Wifi-mesh of #45

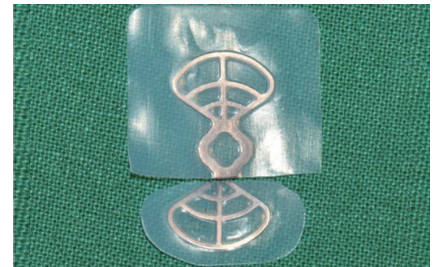

Wifi-Mesh trimming

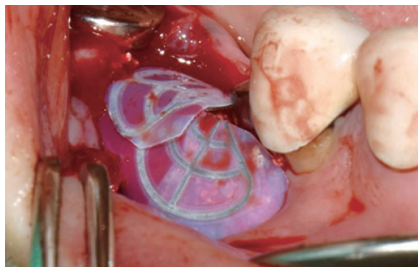

Wifi-Meshes were applied to the defect.

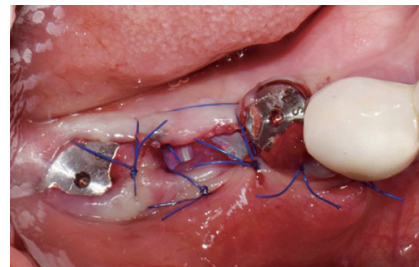

Open membrane technique in extraction socket of #46

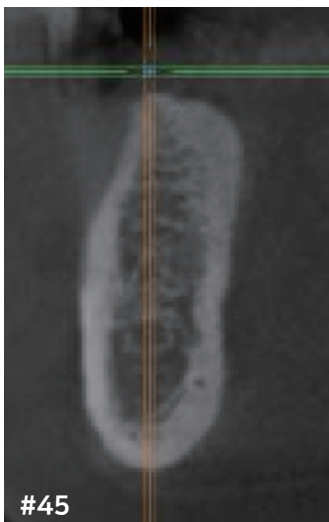

#45

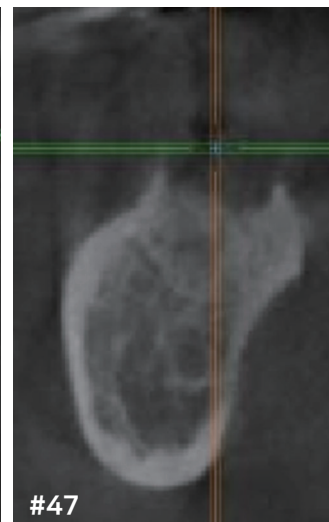
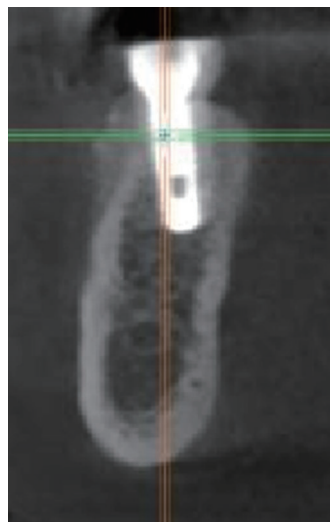

#47

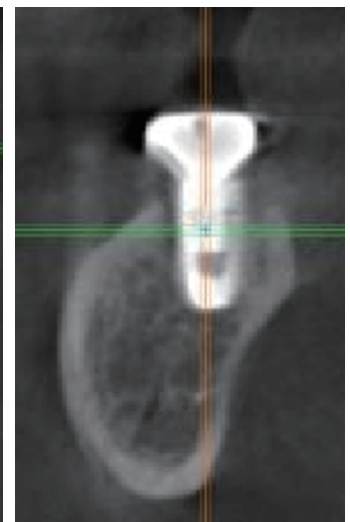



Case II

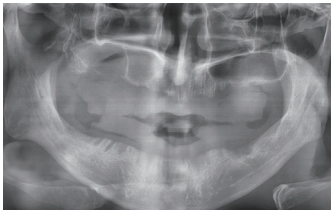

Pre-OP panorama



Occlusal view of the bone defect

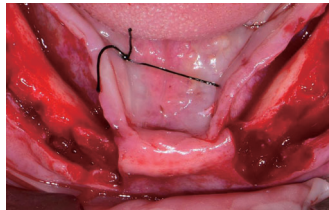

Flap reflection

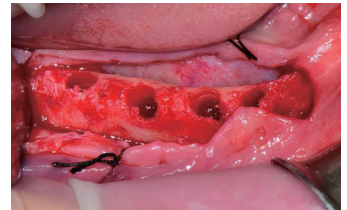

Drilling

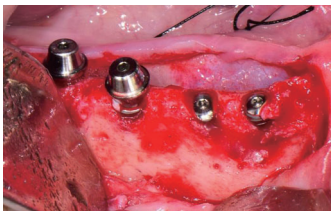

Implant placement of #43, 44, 45 & 46

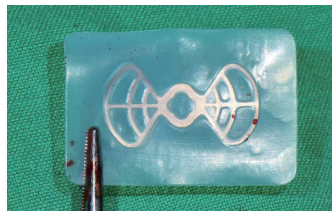

Wifi-Mesh

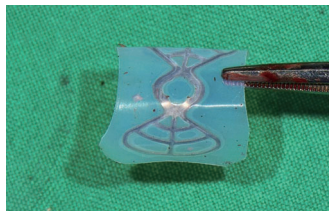

Wifi-mesh preparation*



Wifi-mesh placement

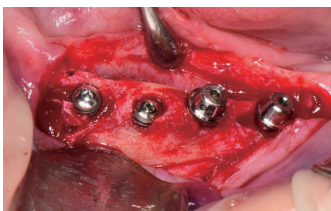

Implant placement of #33, 34, 35 & 36

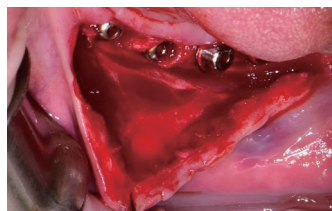

Releasing incision

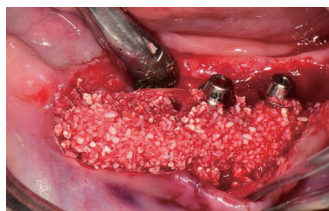

Bone graft

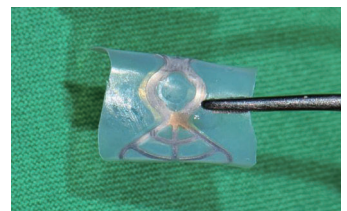

Wifi-mesh preparation

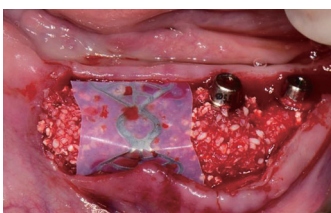

Wifi-Mesh placement

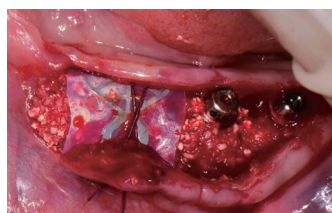

Membrane holding suture



Primary suture



Post OP panorama

* It must be bent to form a shape, and if it is bent incompletely, it can spread inside the gingiva.

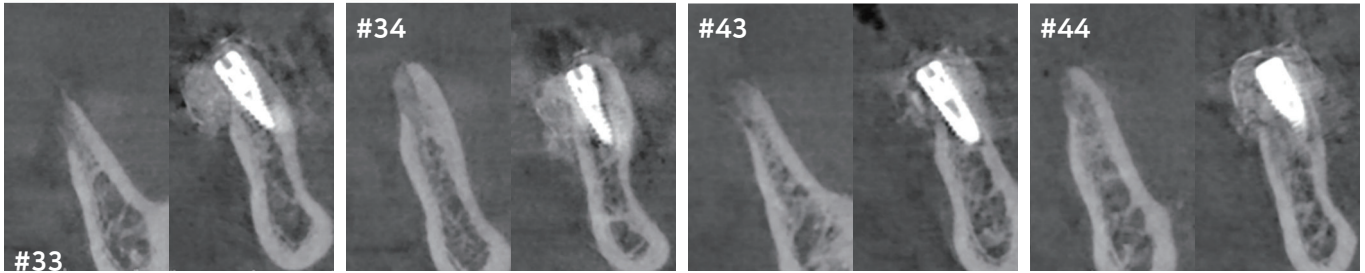

CT scan images after GBR shows significant amount of alveolar bone regeneration.



2 months after the 1st surgery

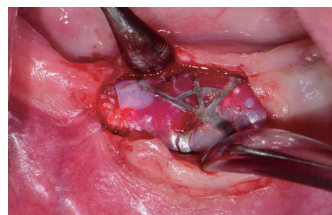

2nd surgery and Wifi-Mesh removal

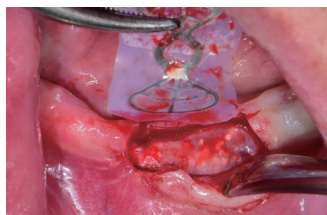

The Wifi-mesh was easily removed.

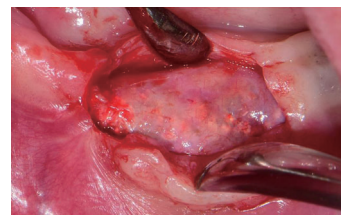

The defect area was fully filled with the new bone.



Installation of healing abutments



Incision of #43 and 44

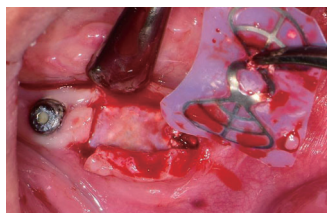

Membrane removal



Both horizontal and vertical bone regeneration was noticed clinically.

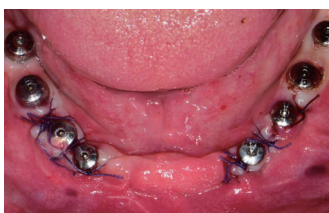

Uncovering surgery of Lower jaw



2nd OP panorama



POD 3 months Temporary loading

Why should I use Wifi-Mesh in GBR?

Although PTFE and titanium are non-resorbable and require a second surgery, Some clinicians report that the d-PTFE completely blocks the penetration of food and bacteria, and thus even if it is exposed to the oral cavity, the d-PTFE membranes exert good guided tissue regeneration (GTR) effects. Wifi-Mesh is made of titanium reinforced d-PTFE. That's why you should use it.

Do the Wifi-Mesh have to be secured with screws or tacks?

The titanium frame is a grade of titanium that has little or no memory, so it may be formed to the desired shape and will remain in that shape until mechanically altered. For this reason, screws or tacks are not always necessary if stability can be obtained by simply tucking the membrane 3-5 mm subperiosteally.

How long can the membrane stay in place?

It is recommended that the membrane stay in place for 3 - 4 weeks. This provides sufficient time for the blood clot to form, graft material to consolidate, and osseous tissue to begin forming under the membrane. The membrane may be left in place longer than 6 weeks, but it is normally recommended to remove the membrane at 3 - 4 weeks to allow revascularization of the soft tissue.

Can unused portions of the titanium reinforced membrane be resterilized?

No. These membranes are single use only and may not be resterilized or reused.

What is the expiration date?

Expiration date of the product is 3 years from manufacturing.



E-COWELLMEDI

(e-cowellmedi.com)



Clinical Videos:

View various clinical videos on your mobile



Operation Cases:

Have more practical ideas for your daily practice



Materials:

Understand COWELLMEDI Products better for predictable and optimal results



1:1 Inquiry

Leave us your question, we will sort out the complications that you may face

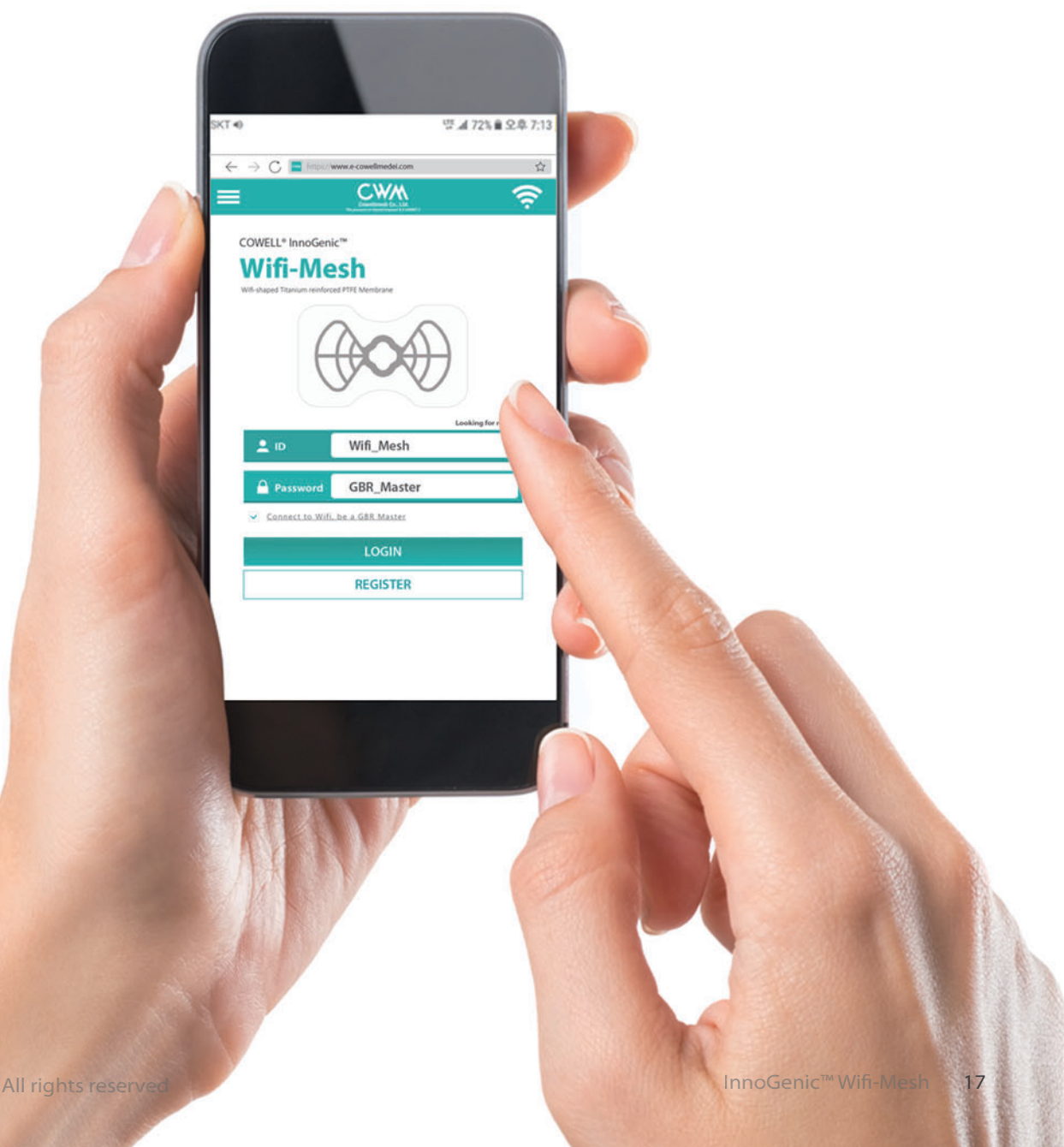

COWELL® InnoGenic™

Wifi-Mesh

Wifi-shaped Titanium reinforced PTFE Membrane

Cowellmedi Co.,Ltd

Floor 6, Blue Fin Tower, 42, Seochojungang-ro, Seocho-gu, Seoul, Korea
Tel. +82-2-3453-5085 Fax. +82-2-3453-5086 E-mail. cib@cowellmedi.com

Cowellmedi USA INC

8507 N. 51ST Avenue Glendale, Arizona 85032
Tel. 1-623-939-1344 Fax. 1-623-939-1472

Cowell R&D Institute

48, Haggam-daero 221beon-gil, Sasang-gu, Busan, 46986, Korea
Tel. +82-51-314-2028 Fax. +82-51-314-2026



Cowellmedi Co., Ltd. www.cowellmedi.com